

Liebert GXT2-6000RTL630™
User Manual - 208 / 240 VAC



TABLE OF CONTENTS

IMPORTANT SAFETY INSTRUCTIONS	1
GLOSSARY OF SYMBOLS	3
1.0 INTRODUCTION	4
2.0 SYSTEM DESCRIPTION	5
2.1 Transient Voltage Surge Suppression (TVSS) and EMI/RFI Filters.....	5
2.2 Rectifier/Power Factor Correction (PFC) Circuit	5
2.3 Inverter	5
2.4 Battery Charger	5
2.5 DC-to-DC Converter.....	6
2.6 Battery	6
2.7 Dynamic Bypass	6
3.0 MAJOR COMPONENTS	7
3.1 Main Frame and Electronics	7
3.2 Internal Battery Packs.....	8
3.3 Removable Power Distribution Box.....	9
4.0 WHAT'S INCLUDED	10
5.0 INSTALLATION AND CONFIGURATION	11
5.1 Install the Main Cabinet	11
5.1.1 Tower UPS Installation	11
5.1.2 Rack-Mount UPS Installation	12
5.1.3 Installing the Adjustable Rack-Mount Kit—Sold Separately	12
5.2 Install the Internal Batteries	14
5.3 Connect the Internal Batteries Using the External Connector.....	15
5.3.1 Storage	15
5.4 Connect Input/Output Power.....	15
5.4.1 Attach Power Distribution Box	16
5.4.2 Distribution Box Electrical Connections.....	17
5.5 External Battery Cabinet Installation	18
6.0 INITIAL START-UP AND ELECTRICAL CHECKS	19
7.0 CONFIGURATION PROGRAM	20
7.1 GXT2-6000RTL630 Configuration Program Features.....	20
7.1.1 What You Will Need.....	20
8.0 CONTROLS AND INDICATORS	21
8.1 ON/Alarm Silence/Manual Battery Test Button	21
8.2 Standby/Manual Bypass Button	21
8.3 Load Level Indicators (4 Green, 1 Amber)	22
8.4 Battery Level Indicators (5 Green)	22
8.5 Fault Indicator LED (Red).....	22

8.6	Bypass Indicator LED (Amber)	22
8.7	UPS ON Indicator LED (Green)	22
8.8	Battery Indicator LED (Amber).	22
8.9	AC Input Indicator LED (Green).	22
9.0	OPERATING INSTRUCTIONS	23
9.1	Normal Mode Operation.	23
9.2	Battery Mode Operation	23
9.3	Bypass Mode Operation	23
9.4	Battery Recharge Mode	23
10.0	COMMUNICATIONS	24
10.1	Communications Interface Port.	24
10.2	Pin 4 - Remote Shutdown on Battery	24
10.3	UPS Intelligent Communications	25
10.4	Remote Emergency Power Off.	26
11.0	MAINTENANCE	27
11.1	Internal Battery	27
	11.1.1 Internal Battery Replacement	28
11.2	AC Power Connections	29
	11.2.1 Disconnect.	29
	11.2.2 Reconnect	30
12.0	TROUBLESHOOTING	31
	12.0.1 Auto-Learning Battery Run Times	35
13.0	SPECIFICATIONS	36

FIGURES

Figure 1	GXT2-6000RTL630, front view	7
Figure 2	GXT2-6000RTL630, rear view	8
Figure 3	Internal battery pack with connector	9
Figure 4	Optional power distribution—PD-L630.	9
Figure 5	Tower-use support bases, spacers for external battery cabinets	11
Figure 6	PD-L630 power distribution box	16
Figure 7	PD-L630 power distribution box electrical connections diagram.	17
Figure 8	Power distribution box, PD-L630.	29

TABLES

Table 1	DB-9 pin assignment	24
Table 2	Indicator meanings	31
Table 3	Troubleshooting guide	32
Table 4	Alarm conditions	33
Table 5	Battery run times	34
Table 6	UPS specifications.	36
Table 7	Internal battery specifications	37
Table 8	Output distribution specifications	37
Table 9	External battery cabinet specifications	38

IMPORTANT SAFETY INSTRUCTIONS

SAVE THESE INSTRUCTIONS



WARNING

Opening or removing the cover may expose you to lethal voltages within this unit even when it is apparently not operating and the input wiring is disconnected from the electrical source.

Observe all cautions and warnings in this manual. Failure to do so may result in serious injury or death. Refer all UPS and battery service to qualified service personnel. Do not attempt to service this product yourself. Never work alone.

SAVE THESE INSTRUCTIONS

This manual contains important safety instructions. Read all safety, installation and operating instructions before operating the Uninterruptible Power Supply (UPS). Adhere to all warnings on the unit and in this manual. Follow all operating and user instructions. Individuals without previous training can install and operate this equipment.

It is not intended for use with life support and other designated critical devices. Maximum load must not exceed that shown on the UPS rating label. The UPS is designed for data processing equipment. If uncertain, consult your local dealer or Liebert representative.

This UPS is designed for use on a properly grounded (earthed), 208, 220, 230 or 240 VAC, 50Hz or 60Hz supply. The factory default setting is 208VAC, 60Hz. Installation instructions and warning notices are located in this manual.

This UPS is for use only with a three-wire input: L1, L2, G.

Electromagnetic Compatibility

The GXT2-6000RTL630 Series complies with the limits for a CLASS A DIGITAL DEVICE, PURSUANT TO Part 15 of FCC rules. Operation is subject to the following two conditions: (1) This device may not cause harmful interference and (2) this device must accept any interference received, including interference that may cause undesired operation. Operating this device in a residential area is likely to cause harmful interference that users must correct at their own expense.

Operate the UPS in an indoor environment only in an ambient temperature range of 32°F to 104°F (0°C to 40°C). Install it in a clean environment, free from conductive contaminants, moisture, flammable liquids, gases and corrosive substances.

This UPS contains no user serviceable parts except the internal battery pack. The Off/Bypass push button does not electrically isolate internal parts. Under no circumstances attempt to gain access internally other than to replace the batteries due to risk of electric shock or burn. Do not continue to use the UPS if the front panel indications are not in accordance with these operating instructions or if the UPS performance alters in use. Refer all faults to your local dealer, Liebert representative or the Liebert Worldwide Support Group.

Servicing of batteries should be performed or supervised by personnel knowledgeable of batteries and the required precautions. Keep unauthorized personnel away from the batteries. **PROPER DISPOSAL OF BATTERIES IS REQUIRED. REFER TO YOUR LOCAL LAWS AND REGULATIONS FOR BATTERY DISPOSAL REQUIREMENTS.**

Never block or insert any object into the ventilation holes or other openings of the UPS.

DO NOT CONNECT equipment that could overload the UPS or demand half-wave rectification from the UPS, for example: electric drills, vacuum cleaners, laser printers, hair dryers or any other appliance using half-wave rectification.

Storing magnetic media on top of the UPS may result in data loss or corruption.

Turn the UPS off and isolate the UPS before cleaning; use only a soft cloth, never liquid or aerosol cleaners. Keep the front and rear vents free of dust accumulation that could restrict airflow.

When replacing batteries, replace with the same Liebert authorized replacement battery kits.



CAUTION

Do not dispose of battery or batteries in a fire. The battery may explode.

Do not open or mutilate the battery or batteries. Released electrolyte is harmful to skin and eyes. It is toxic.

















CAUTION

A battery can present a risk of electrical shock and high short circuit current. The following precautions should be observed when working on batteries:

- Remove watches, rings and other metal objects.
- Use tools with insulated handles.
- Wear rubber gloves and boots.
- Do not lay tools or metal parts on top of batteries.
- Disconnect charging source prior to connecting or disconnecting battery terminals.

GLOSSARY OF SYMBOLS

	Risk of electrical shock
	Indicates caution followed by important instructions
	AC input
	AC output
	Requests the user to consult the manual
	Indicates the unit contains a valve-regulated lead acid battery
	Recycle
	DC voltage
	Equipment grounding conductor
	Bonded to ground
	AC voltage
	ON/Alarm Silence/Battery Test
	OFF/Bypass
	Indicates the position of a fuse

1.0 INTRODUCTION

Congratulations on your choice of the Liebert GXT2-6000RTL630 Uninterruptible Power Supply (UPS). It provides conditioned power to microcomputers and other sensitive electronic equipment.

Upon generation, AC power is clean and stable. However, during transmission and distribution it may be subject to voltage sags, spikes or complete power failure that may interrupt computer operations, cause data loss or even damage equipment. The GXT2-6000RTL630 protects equipment from these disturbances.

The GXT2-6000RTL630 comes in a nominal power rating of 6000 VA. Complete model specifications appear at the end of this manual.

The GXT2-6000RTL630 is a compact, on-line UPS. An on-line UPS continuously conditions and regulates its output voltage, whether utility power is present or not. It supplies connected equipment with clean sinewave power. Sensitive electronic equipment operates best from sinewave power.

For ease of use, the GXT2-6000RTL630 features a light-emitting diode (LED) display to indicate both load percentage and battery capacity. It also provides self-diagnostic tests, a combination ON/Alarm Silence/Manual Battery Test button, a Standby button, user configurable program, and two levels of alarms when the unit is operating on battery.

The GXT2-6000RTL630 has an interface port for communication between the UPS and a network server or other computer systems. This port provides detailed operating information including voltages, currents, and alarm status to the host system when used in conjunction with Liebert MultiLink™ software. MultiLink software can also remotely control UPS operation.

2.0 SYSTEM DESCRIPTION

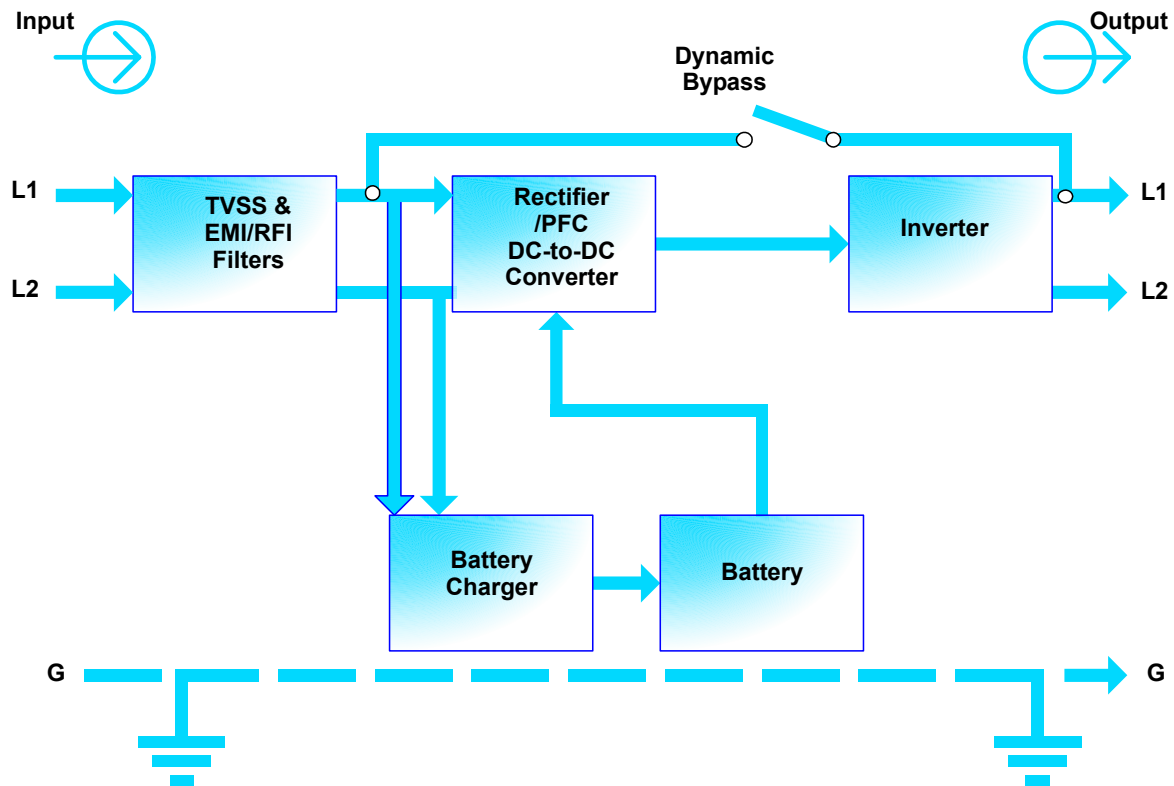

2.1 Transient Voltage Surge Suppression (TVSS) and EMI/RFI Filters

These UPS components provide surge protection and filter both electromagnetic interference (EMI) and radio frequency interference (RFI). They minimize any surges or interference present in the utility line and keep the sensitive equipment protected.

2.2 Rectifier/Power Factor Correction (PFC) Circuit

In normal operation, the rectifier/power factor correction (PFC) circuit converts utility AC power to regulated DC power for use by the inverter while ensuring that the waveshape of the input current used by the UPS is near ideal. Extracting this sinewave input current achieves two objectives:

- The utility power is used as efficiently as possible by the UPS.
- The amount of distortion reflected on the utility is reduced.

This results in cleaner power being available to other devices in the building not being protected by the GXT2-6000RTL630.

2.3 Inverter

In normal operation, the inverter utilizes the DC output of the power factor correction circuit and inverts it into precise, regulated sinewave AC power. Upon a utility power failure, the inverter receives its required energy from the battery through the DC to DC converter. In both modes of operation, the UPS inverter is on-line and continuously generating clean, precise, regulated AC output power.

2.4 Battery Charger

The battery charger utilizes energy from the utility power and precisely regulates it to continuously float charge the batteries. The batteries are being charged whenever the GXT2-6000RTL630 is connected to utility power.

2.5 DC-to-DC Converter

The DC to DC converter utilizes energy from the battery system and raises the DC voltage to the optimum operating voltage for the inverter. This allows the inverter to operate continuously at its optimum efficiency and voltage, thus increasing reliability.

2.6 Battery

The GXT2-6000RTL630 utilizes valve-regulated, nonspillable, lead acid batteries. To maintain battery design life, operate the UPS in an ambient temperature of 68°F to 77°F (20°C to 25°C). Optional external battery cabinets are available to extend battery run times.

2.7 Dynamic Bypass

The GXT2-6000RTL630 provides an alternate path for utility power to the connected load in the unlikely event of a UPS malfunction. Should the UPS have an overload, overtemperature, or UPS failure condition, the UPS automatically transfers the connected load to bypass. Bypass operation is indicated by an audible alarm and illuminated amber Bypass LED (other LEDs may be illuminated to indicate the diagnosed problem). To manually transfer the connected load from the inverter to bypass, press the Standby button once.



NOTE

The bypass power path does NOT protect the connected equipment from disturbances in the utility supply.

3.0 MAJOR COMPONENTS

The GXT2-6000RTL630 is composed of three major assemblies to provide easier handling, installation, and versatility.

3.1 Main Frame and Electronics

This 5U cabinet is shipped without internal batteries to lighten the UPS for easier installation. The internal batteries may be installed after the cabinet has been placed in its final floor or rack position. The Power Distribution box is shipped separately for easier handling of the UPS while being placed in its final position.

Figure 1 GXT2-6000RTL630, front view

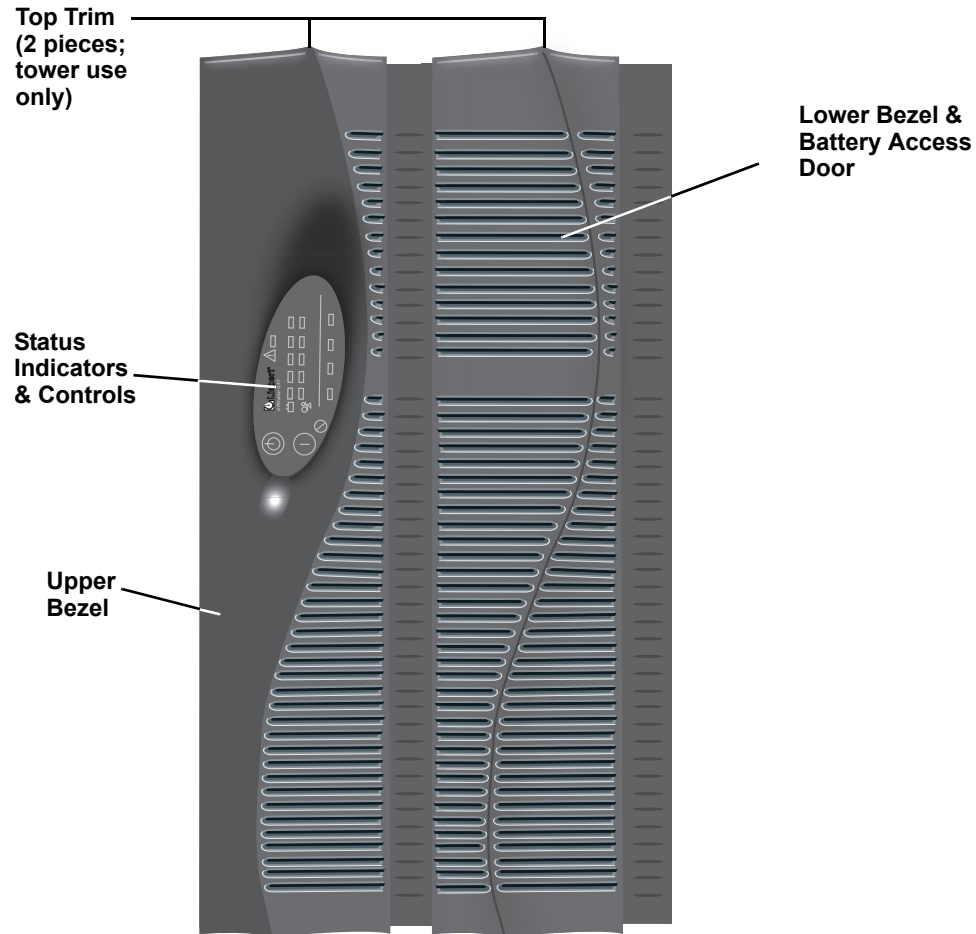
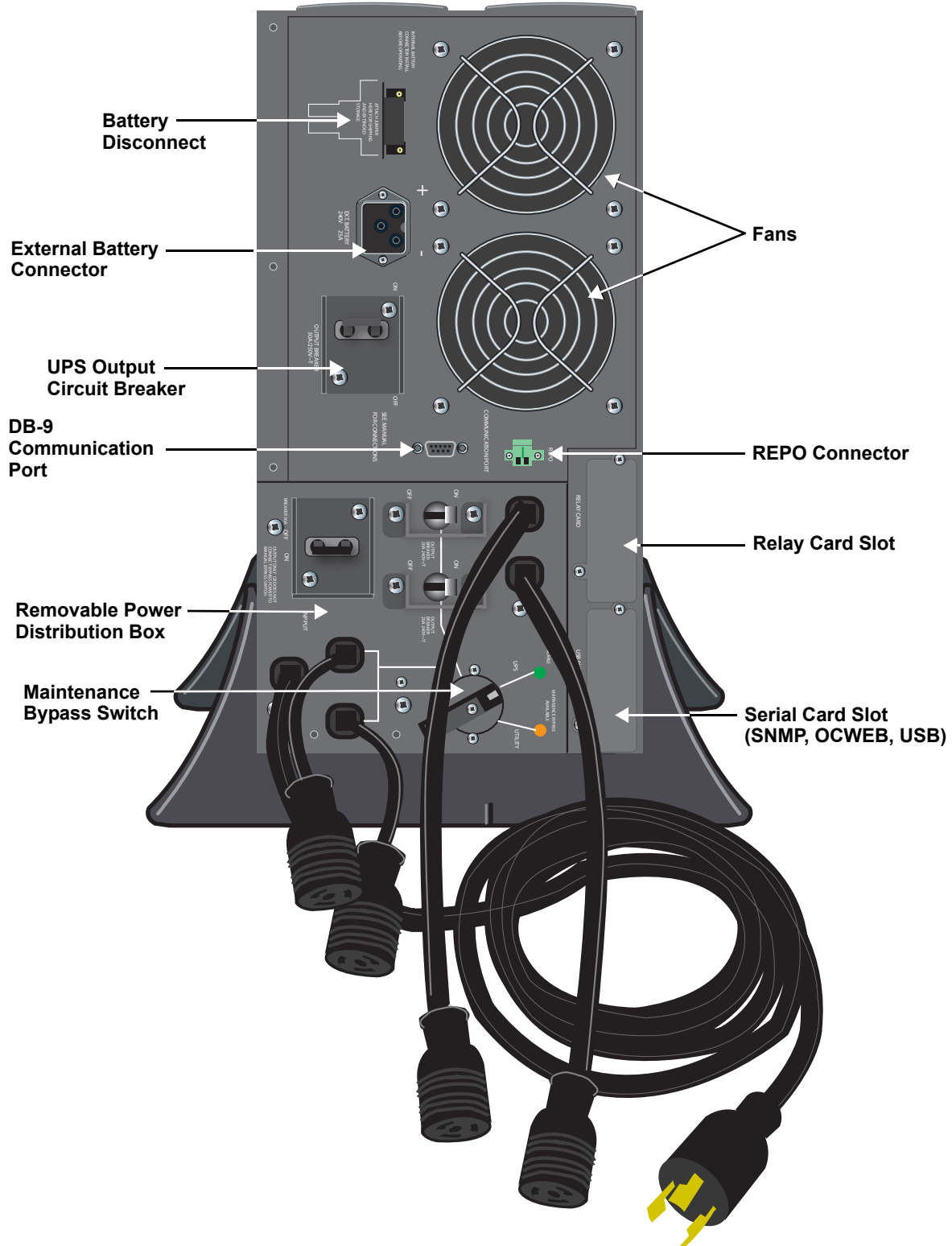

Figure 2 GXT2-6000RTL630, rear view



3.2 Internal Battery Packs

The UPS has two internal battery packs behind a battery access door on the front of the unit. Each pack is fitted with a connector to link to the UPS. The batteries are shipped in packaging separate from the UPS. These must be installed before the UPS may be put into service. For installation instructions, see **5.2 - Install the Internal Batteries**.

Figure 3 Internal battery pack with connector

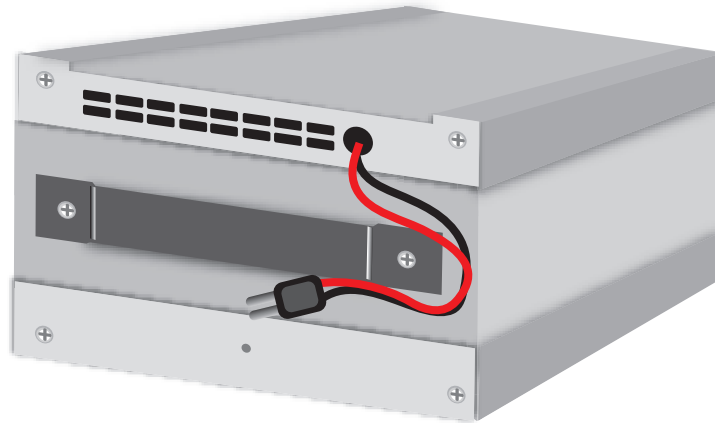

3.3 Removable Power Distribution Box

The UPS incorporates a power distribution box that must be installed before the unit is placed into service. The power distribution box provides the benefits of plug and receptacle convenience with a manual bypass switch. For installation instructions, see **5.4 - Connect Input/Output Power**.

Optional versions may be available to replace the standard box for custom installations.

Figure 4 Optional power distribution—PD-L630

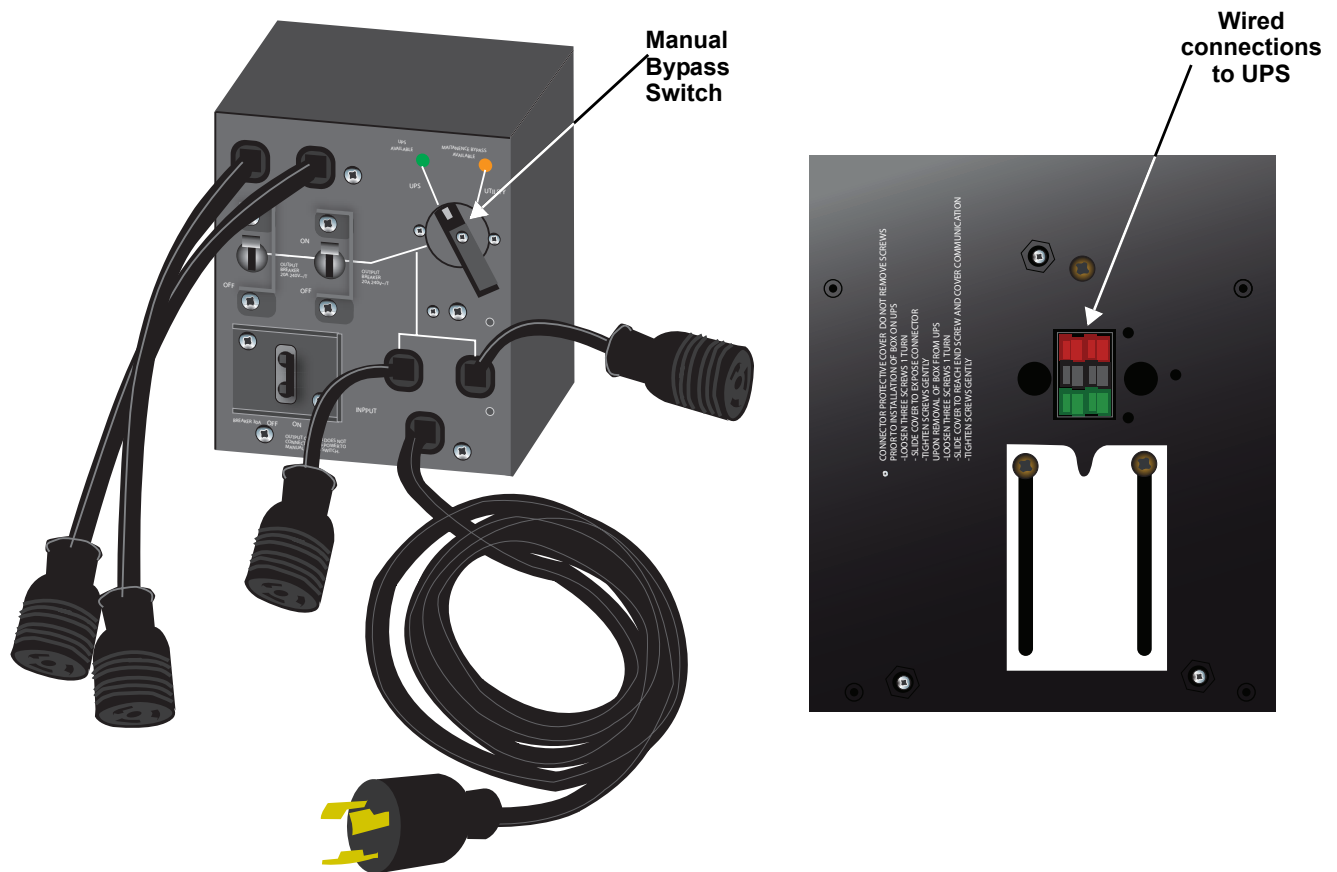

4.0 WHAT'S INCLUDED

The GXT2-6000RTL630 is shipped with the following items:

- GXT2-6000RTL630 user manual
- Vertical display overlay
- Top bezels - 2
- MultiLink software CD
- MultiLink serial cable, 10 ft (3m)
- Rack mount handles
- Battery retaining brackets and screws - 2 each
- Support base - 2
- Mounting hardware
- Configuration program CD
- DB-9 port cover

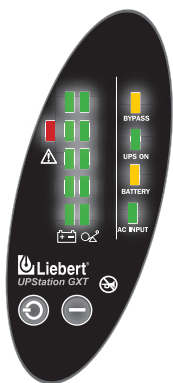

Vertical display overlay



Top bezels (tower use)

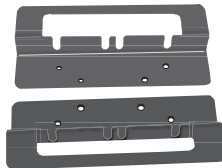

Rack mount handles



MultiLink software CD

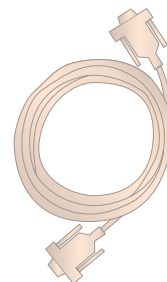

MultiLink serial cable 10 ft (3m)

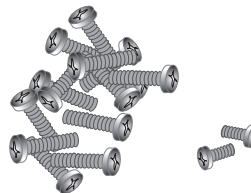

Mounting hardware

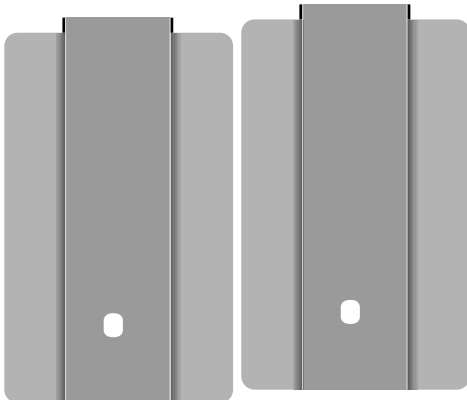

Battery retaining brackets and screws

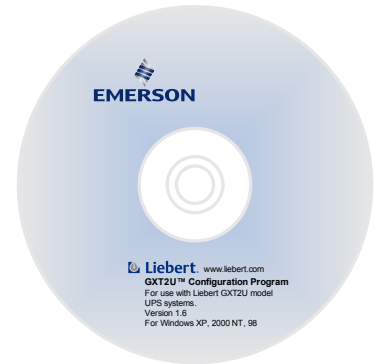

Configuration disk

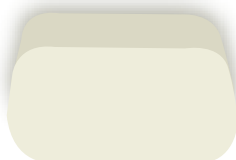

DB-9 port cover

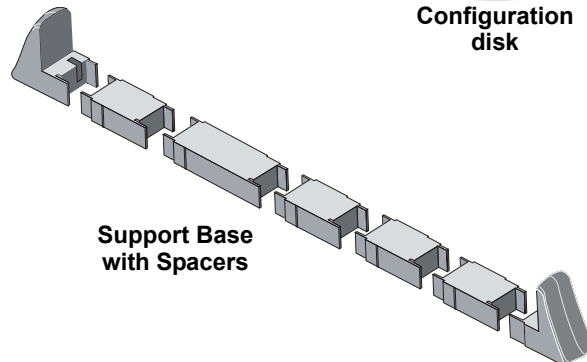

Support Base with Spacers

5.0 INSTALLATION AND CONFIGURATION

Do NOT attempt to start the UPS, turn on any circuit breaker or energize the input power until instructed to do so in **6.0 - Initial Start-Up and Electrical Checks**.

Visually inspect the UPS for freight damage. Report any damage to the carrier and your local dealer or Liebert representative.



CAUTION

The UPS is heavy (see **13.0 - Specifications**). Take proper precautions when lifting or moving it.

Install the UPS indoors in a controlled environment, where it cannot be accidentally turned off. Place it where air flows unrestricted around the unit. The installation location must be free of water, flammable liquids, gases, corrosives and conductive contaminants. Maintain a minimum clearance of 4 inches (100mm) in the front and rear of the UPS. Maintain an ambient temperature range of 32-104°F (0 to 40°C).



NOTE

UPS operation in sustained temperatures above 77°F (25°C) reduces battery life.

5.1 Install the Main Cabinet

The GXT2-6000RTL630 may be installed in either a tower configuration or in a rack, depending on available space and use considerations. Determine the type of installation and follow the appropriate instructions in either **5.1.1 - Tower UPS Installation** or **5.1.2 - Rack-Mount UPS Installation**.

5.1.1 Tower UPS Installation

When using the GXT2-6000RTL630 in a tower configuration, use the included support base (shown below, left) to stabilize the UPS. If any external battery cabinets are added, they will include spacers to accommodate the additional cabinets (shown below, right).

Attach Bezels to Top

When used as a tower, the GXT2-6000RTL630 requires bezels attached to the top. To connect the bezels:

1. Position the UPS so that the battery compartments are on the right side.
2. Attach the top bezels by placing them on the mounting holes and sliding them toward the rear of the UPS.

Figure 5 Tower-use support bases, spacers for external battery cabinets

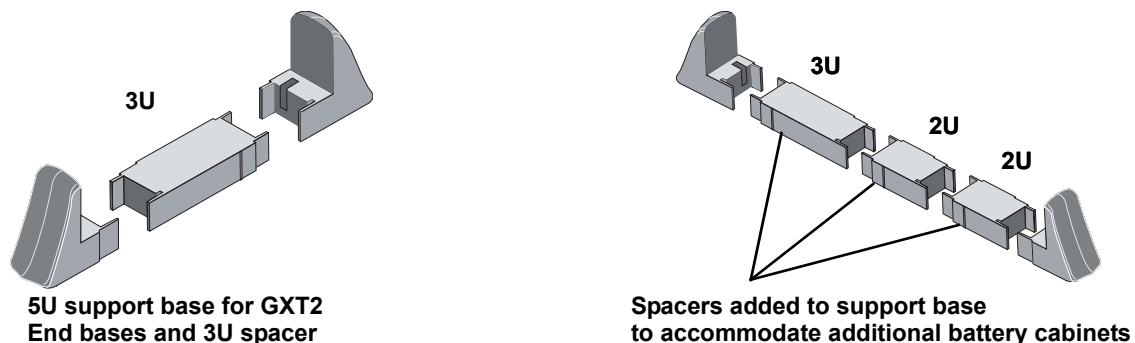

5.1.2 Rack-Mount UPS Installation

When using the GXT2 in a rack-mount configuration, the UPS must be supported by a slide kit, fixed rails or a shelf.

When using the optional Adjustable Rack Mount Kit, you will use the following instructions. The figures accompanying **5.1.3 - Installing the Adjustable Rack-Mount Kit—Sold Separately** shows the positioning of the rack-mounting brackets. Liebert recommends taking the internal batteries out of the UPS during rack installation. This will make the UPS cabinet lighter and easier to handle.



CAUTION

Only three (3) M4 screws are used on the side of the GXT2 where the Power Distribution Box is located. The fourth mounting hole is above the Power Distribution Box and is not used.

5.1.3 Installing the Adjustable Rack-Mount Kit—Sold Separately

This kit contains parts needed to mount several different models of UPS and external battery cabinets into EIA310-D standard four-post racks that are 18-32" deep (457-813mm). The weight limit per pair of adjustable rack-mounting brackets is 200 lb (91kg).

Parts included are:

Item	Quantity
Rear bracket members	2
Front bracket members	2
Inner bracket members	2
M4 x 8mm machine screws	16
M4 locking hex nuts	8
M5 x 16 mm machine screws	12
Grease packet.	1

Tools needed for installation are:

- one Phillips screwdriver
- one 7mm wrench

The adjustable rack-mounting brackets (Part#: RMKIT18-32) feature retaining latches to prevent users from inadvertently sliding the UPS or battery cabinet out of the rack.

To install the rack mount brackets:

1. Unpack two (2) rack-mounting bracket assemblies and mounting hardware from this kit. Bracket assemblies are interchangeable between left-hand or right-hand. Remove inner member of each bracket assembly as shown at right by extending it to its outermost position, depressing the retaining latch and then pulling the inner member out of the bracket assembly.
2. Determine the height position inside the rack enclosure where you want to mount the UPS or battery cabinet.

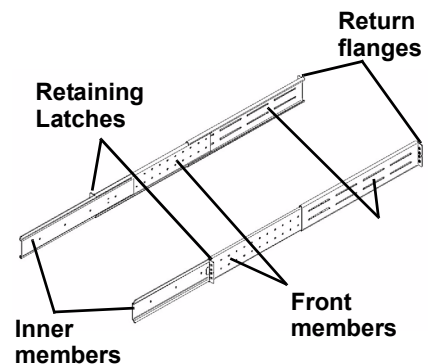

CAUTION

Reduce the risk of tipping the rack enclosure by placing the UPS or battery cabinet in the lowest possible rack position.

3. Install the rear member of each bracket assembly into the rack enclosure with two (2) M5 screws provided in this kit (see figure at right). The return flanges on the bracket assembly fit to the inside of rack mounting rails. Insert screws loosely (finger-tight) into the top and bottom holes of the return flange on the rear member. Extend the bracket assembly by sliding the front member forward until it touches the front rack mounting rail. Insert two (2) M5 screws loosely (finger-tight) into the top and bottom holes of the return flange on each front member. Make sure that the bracket assemblies are at the same mounting height on all four (4) rack mounting rails.
4. Get eight (8) M4 screws and eight (8) M4 nuts from the hardware pack in this kit. Each nut has a locking, nylon insert that begins gripping the screw when it is halfway tight. Make sure to tighten the nut and screw completely to ensure locking action. Fasten the rear member and the front member together using (4) screws and (4) nuts per bracket assembly as shown in at right. For maximum support, insert fasteners for each bracket assembly as far apart as possible, depending on rack depth, while still joining both members (see figures at right). Check alignment of bracket assemblies and **TIGHTEN ALL SCREWS FROM Steps 2 and 3.**
5. Prepare the UPS or battery cabinet (the “equipment”) for rack mounting by following instructions in the equipment’s user manual. The equipment may require additional parts to be added or parts to be removed for rack mounting. After it is prepared, lay the equipment in rack-mounting position. Fasten the inner members from **Step 1** to the equipment on both sides as shown at right with seven (7) M4 screws provided in the kit. Make sure retaining latch is near the rear of the equipment as shown (see figure below right).
6. Open the grease packet provided in the kit. Apply a bead of grease 25mm (1") long at four (4) places inside the bottom, curved tracks of the front members as shown below right. The grease will allow the equipment to slide into the bracket assemblies more easily.

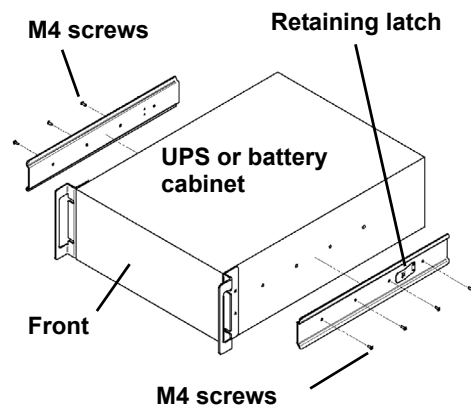
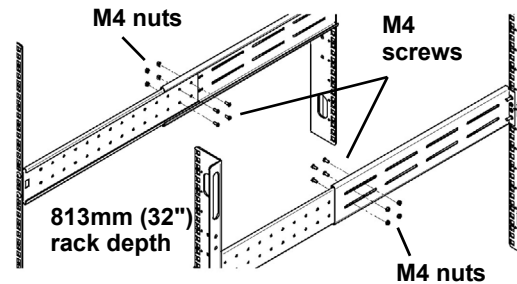
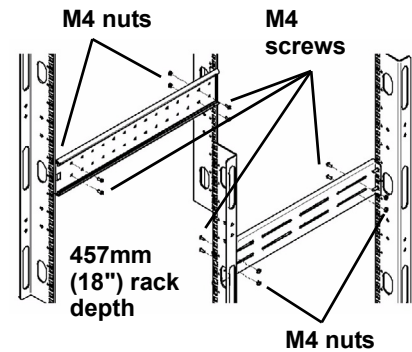
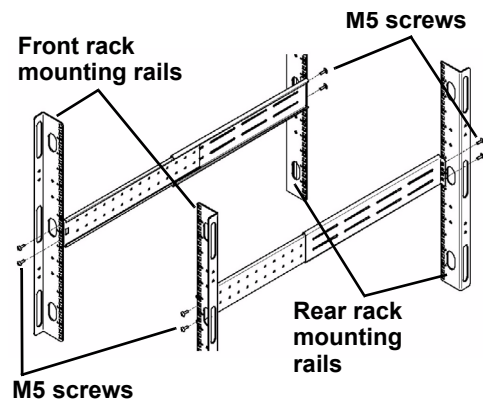

CAUTION

Lifting equipment into the rack may be a two-person job, depending on the weight of the equipment. Liebert recommends taking the internal batteries out of the UPS during rack installation. This will make the UPS cabinet lighter and easier to handle. The GXT2-6000RTL630 weighs 151 lb (67kg). For the battery cabinet’s weight, see the unit’s user manual.

7. Insert the equipment, with inner members attached in **Step 5**, into the bracket assemblies by inserting the top and bottom edges of the inner members into the top and bottom curved tracks of the front members and sliding the equipment into the rack (see figure at right). Ends of inner members are tapered to allow the rear of the equipment to be angled upward before insertion, if space allows.

Then the rear, bottom edges of the inner members can be placed into the front edge of the bottom tracks and the front of the equipment can be tipped up so they are level to insert the top edges of the inner members before sliding the equipment into the rack (see figure below right). The equipment should move smoothly into the bracket assemblies. If it does not, recheck the alignment of the front and rear members from **Steps 2** and **3**.

8. Secure the front of the equipment to the rack mounting rails to prevent the equipment from sliding out of position. If securing holes are provided on the front of the equipment that align with the center holes on the return flange of the front members, you can use the four (4) extra M5 screws provided in the kit to secure the equipment. Otherwise, the equipment should be secured to the front of the rack with four (4) customer-supplied fasteners.

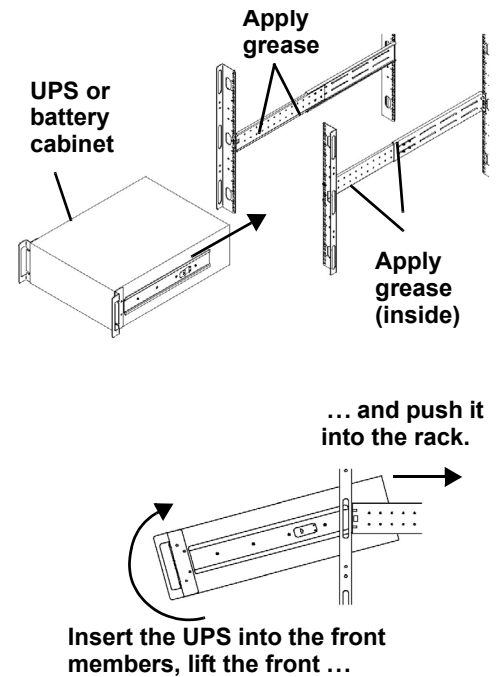

5.2 Install the Internal Batteries

For ease of installation and configuration, the GXT2-6000RTL630 is shipped without its internal batteries installed. After the UPS is prepared and installed as either a tower or in a rack, install the GXT2-240BATKIT battery packs.

To install the internal batteries:



CAUTION

A battery can present a risk of electrical shock and high short circuit current. Observe the following precautions before replacing the batteries:

- Remove rings, watches and other metal objects.
- Use a Phillips (cross-head) screwdriver with insulated grips.
- Do not lay tools or other metal objects on top of the batteries.
- If the battery replacement kit is damaged in any way or shows signs of leakage, contact your local dealer or Liebert representative immediately.
- Do not dispose of batteries in a fire. The batteries may explode.
- Do not open or mutilate batteries. Released electrolyte is harmful to the skin and eyes. It is toxic.

1. Remove the 3U battery access panel on the front of the GXT2-6000RTL630 by loosening the two captive screws located between the bezels (see illustration at left).

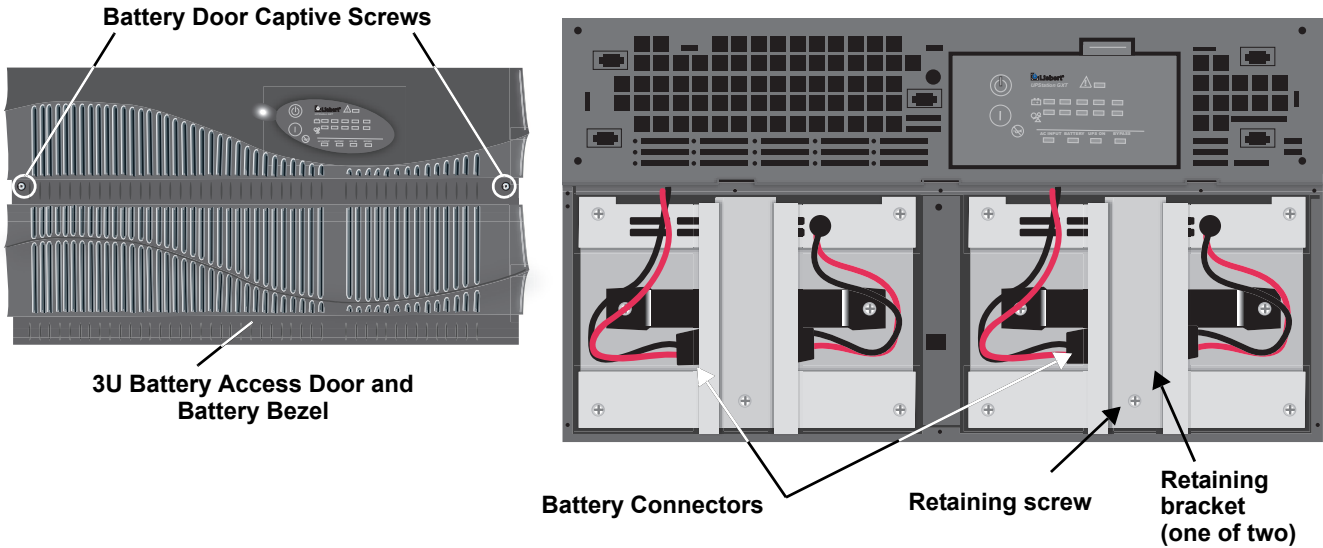

2. Once the captive screws are loosened, tip the panel forward and lift to remove it from the main cabinet.
3. Unpack the GXT2-240BATKIT battery assembly.
4. Line up and slide in the battery pack while holding the internal connector out of the way.
5. Connect the electrical cables to each battery pack with the two slotted battery connectors.
6. Install the battery retaining brackets supplied in the accessory box.
7. Install the battery access panel and tighten the captive screws.

5.3 Connect the Internal Batteries Using the External Connector

The connector attaches to the UPS in both the open and closed position using two screws. The picture on the left shows the connector in the open position, as shipped.

When the UPS is installed, remove the two screws to release the connector. Plug the connector into the socket. The internal batteries are now connected to the UPS electronics. Install the two screws to secure the connector in the closed position.

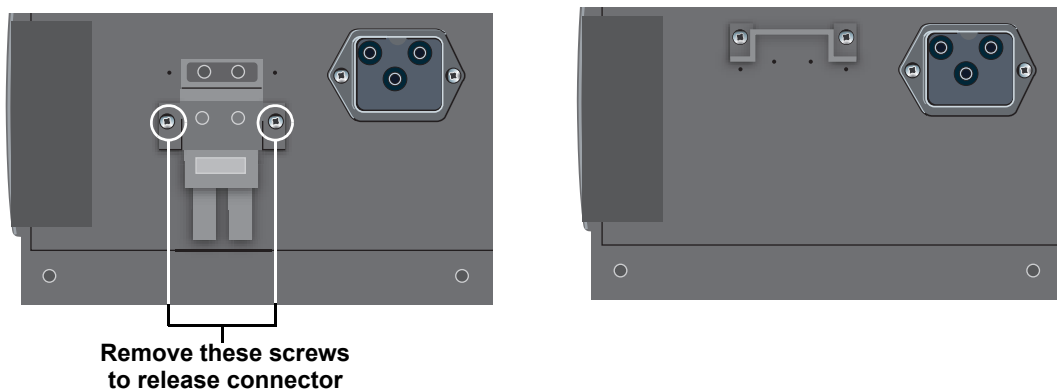

5.3.1 Storage

If the UPS is to be shipped or stored for an extended time, the connector should be removed and attached in the open position, as shown above. This will minimize any standby current drain on the batteries.

5.4 Connect Input/Output Power

The Power Distribution box is shipped separately for easier handling of the UPS while the UPS is being placed in its final position.

5.4.1 Attach Power Distribution Box

Whenever the power distribution box is not attached to the UPS, the cover must be slid over the electrical connections to prevent damage or injury.

To attach the PD-L630 power distribution box to the UPS:

1. Loosen the white cover over the electrical connections by backing out the three screws securing the cover one turn each.
2. Slide the cover open to expose the electrical connectors.
3. Gently retighten the three screws loosened in **Step 1**.
4. Align the connectors on the box and UPS.
5. Push the box into place.
6. Holding the box firmly against the UPS, tighten the three captive mounting screws until the box is secure. Do not overtighten.

Figure 6 PD-L630 power distribution box

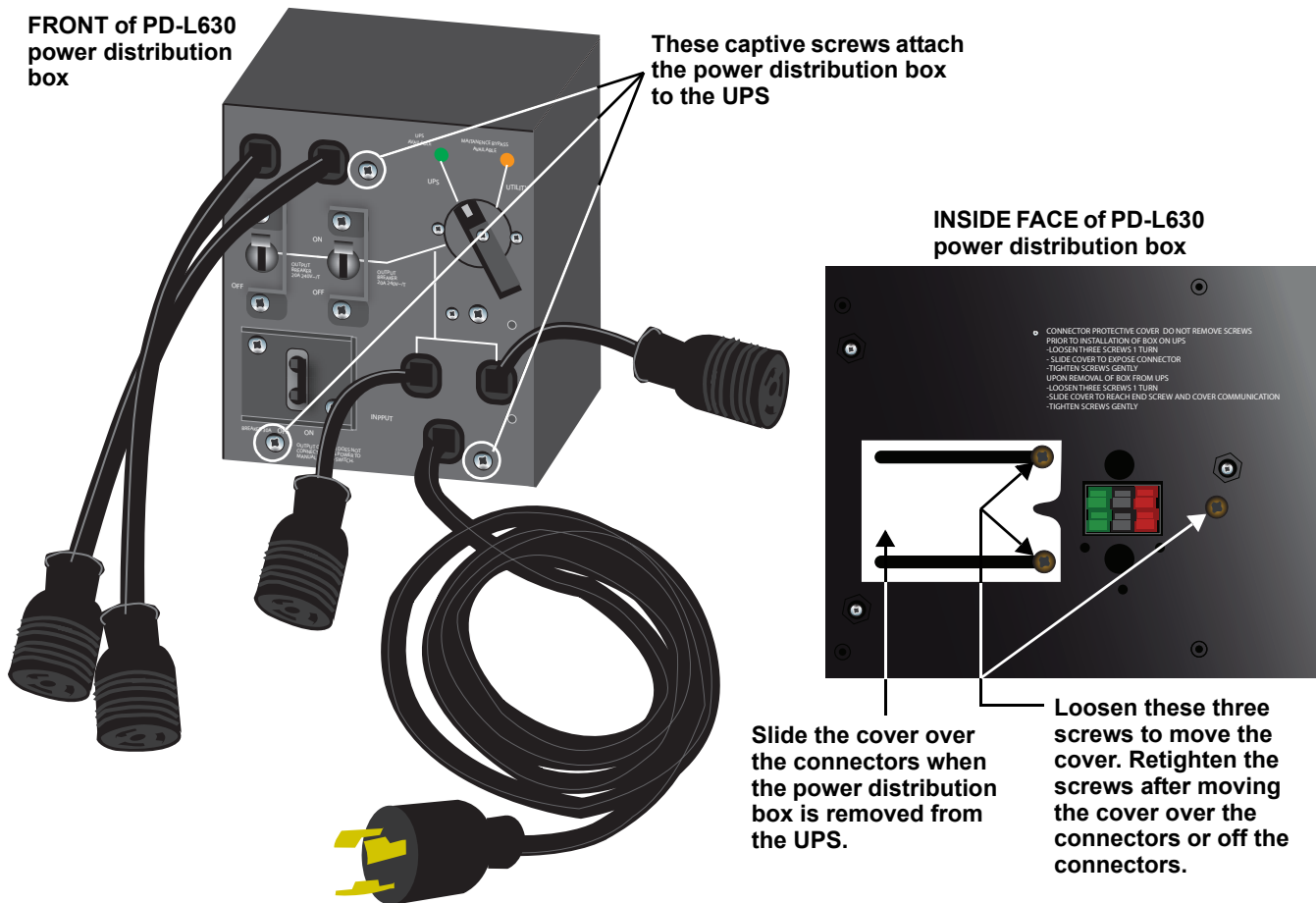

5.4.2 Distribution Box Electrical Connections

Electrical connections are made through a removable power distribution box that attaches to the rear of the UPS.

The installer must provide a 30A branch circuit breaker, with NEMA L6-30R receptacle. The Input circuit breaker on the distribution box and the Output circuit breaker on the rear fixed-panel of the UPS disconnect all power between the main cabinet and the distribution box.

Models equipped with a manual bypass switch pass bypass power directly to the bypass switch from the input power cord. The input circuit breaker on the distribution box does not disconnect power from the manual bypass switch.

Figure 7 PD-L630 power distribution box electrical connections diagram

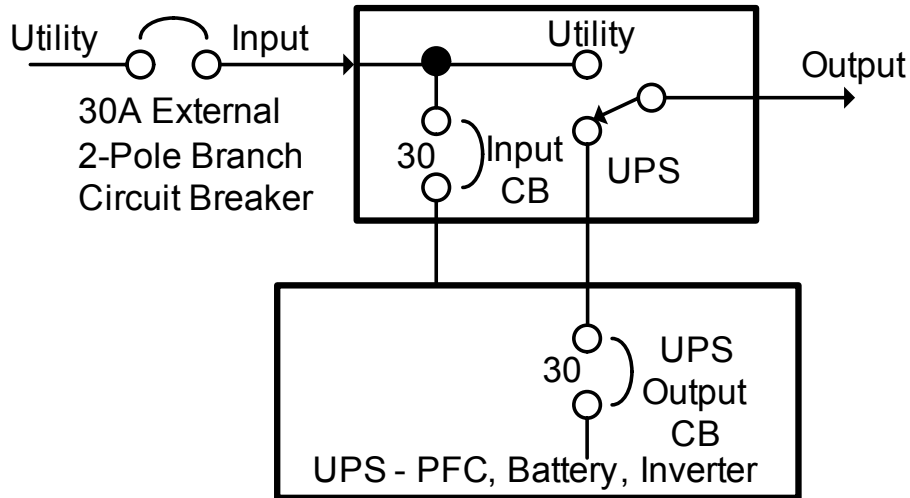

5.5 External Battery Cabinet Installation

Optional Liebert external battery cabinets may be connected to the UPS to provide additional battery run time. External battery cabinets are designed to be placed on one side of the UPS or stacked beneath the UPS.



CAUTION

The external battery cabinet(s) are heavy (see **13.0 - Specifications**). External battery cabinets can be used in rack-mount or tower configuration. Take proper precautions when lifting them.

1. Visually inspect the external battery cabinet for freight damage. Report damage to the carrier and your local dealer or Liebert representative.
2. For slide rail installations, first remove the top/side fin. Top/side fin slides forward and then lift up to remove. Optional rack-mount handles are shipped with the external battery cabinet and may be installed at this time if desired.
3. Securing hardware and slide rails are sold separately. Please contact your local dealer or Liebert representative for these additional options and any assistance needed. Fasten the slides into position with the screws per the instructions included with the slide rails.
4. Use the enclosed support bases for the tower option to prevent tip-over. One additional set of support base extensions ships with each external battery cabinet.
5. Connect the supplied external battery cabinet cable to the rear of the external battery cabinet, then to the rear of the UPS.
6. The UPS is now equipped with additional backup battery run time. For approximate battery run times, refer to **Table 5**.



CAUTION

Do not turn on (close) the battery cabinet circuit breaker yet. Complete the installation first.



NOTE

You must use the included configuration program to program the UPS for the number of external battery cabinets connected. Instructions for the configuration program are in **7.0 - Configuration Program**.

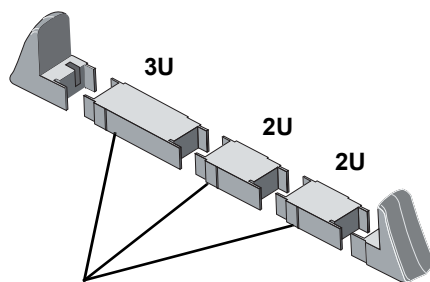

Spacers added to support base to accommodate additional battery cabinets

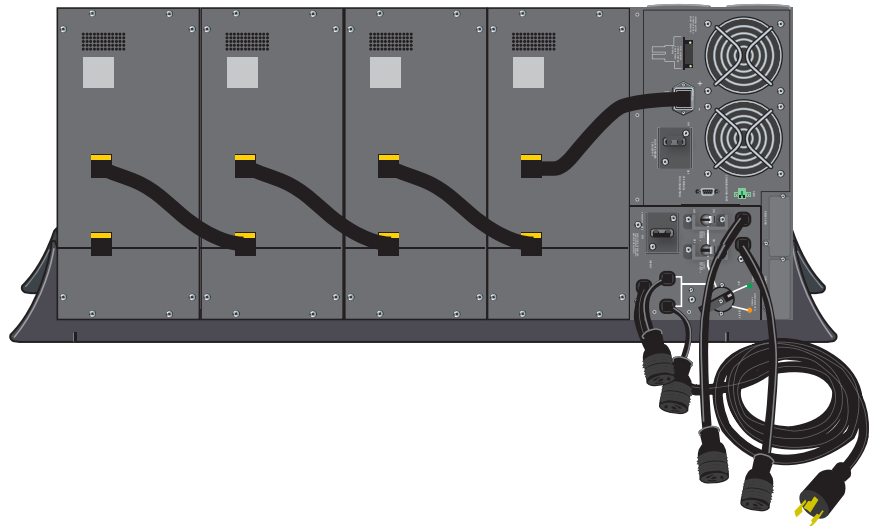

6.0 INITIAL START-UP AND ELECTRICAL CHECKS

1. Verify that the input and output circuit breakers are off (open).
2. During initial system checks, disconnect all loads (open load disconnects).
3. Inspect all wiring, cables, and connection.
4. If external battery cabinets are used, verify that the battery interconnect cables are fully inserted in the sockets.
5. Turn on (close) the battery cabinet circuit breaker.
6. On the power distribution box, place the Manual Bypass Switch in the UTILITY position.
7. Turn on (close) the branch circuit disconnect to apply voltage to the input.
8. Using a voltmeter, verify the expected L1-L2 voltage.
Verify the same voltage is measured at the output receptacles.
The BYPASS lamp by the Manual Bypass Switch will light.
9. After verifying proper input voltage to the UPS, turn on the Input circuit breaker located on the distribution box. The green AC Input indicator should illuminate on the UPS' front panel.
10. Press the On button for 1 second. The BYPASS lamp will light for several seconds before the UPS ON lamp turns on continuously. If the batteries are determined to be charged above 80%, an automatic battery test will run for about 15 seconds.
11. Turn on (close) the output circuit breaker on the rear of the UPS. The UPS lamp on the power distribution box by the Manual Bypass Switch will light. Transfer the switch to the UPS position. The output will now be powered by the UPS.
12. Perform a Manual Battery Test - Press the ON button for 1 second. The front BATTERY lamp will light for about 15 seconds and then return to only the UPS ON and AC INPUT lamps being on.
13. Review all setting options provided by the configuration program. Some changes require that the UPS be Off. If this is the case, these should be programmed before powering the loads. The configuration program is described in **7.0 - Configuration Program**.
14. Connect all loads for normal operation.

7.0 CONFIGURATION PROGRAM

The final step of installation may require custom configuration of your UPS using the enclosed configuration program. Some configuration settings may be changed only while the UPS is off. These should be set before the UPS is put into full-time service powering the critical load.

For most users operating with 208VAC and with no external batteries, the factory default settings will be adequate.

The configuration program user manual is included as a PDF on the CD that shipped with the UPS.

7.1 GXT2-6000RTL630 Configuration Program Features

- Select one of four L-L output voltages to match local voltages.
- Enable/Disable Auto-Restart.
- Select frequency converter operation with a fixed output frequency of 50 or 60 Hz.
- Set the Low Battery Warning alarm time from 2 to 30 minutes.
- Enable/Disable the Auto-Battery test.
- Set the Auto-Battery test to 7, 14, 21, or 28 days.
- Specify the number of external battery cabinets connected to the UPS to adjust the remaining run time calculations reported by Liebert software products.
- Modify the shutdown setting of DB-9 pin 6 (for information on pin assignments, see **Table 1**).

7.1.1 What You Will Need

In addition to the GXT2 UPS, you will need the configuration program CD and serial cable (beige or tan, 3-wire: GND, TX, RX; straight through 2-2, 3-3, 5-5) included in the UPS accessory box. A Windows 95® or later computer, desktop or laptop, is also required to set up and run the configuration program.

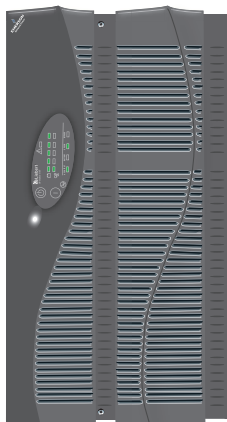

GXT2-6000RTL630

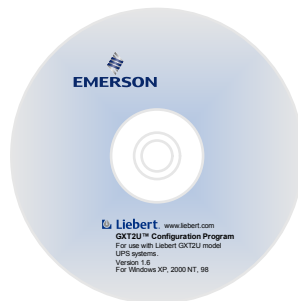

Configuration Program CD

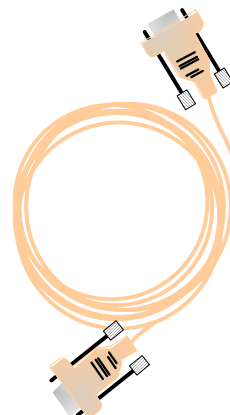

Serial Cable



Laptop

8.0 CONTROLS AND INDICATORS

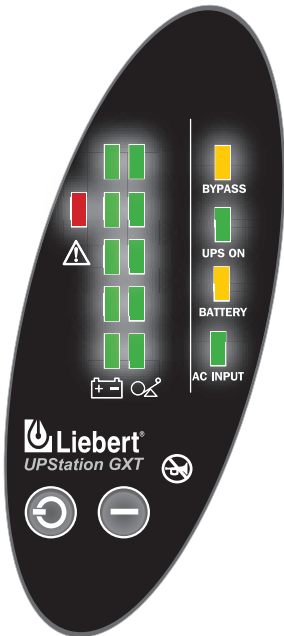

All indicators illuminated for illustration only.

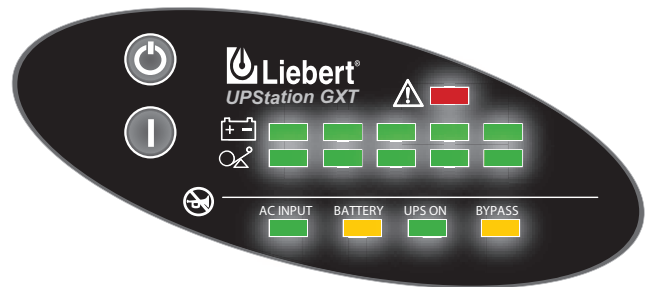

8.1 ON/Alarm Silence/Manual Battery Test Button

This button controls output power to connected load(s) and has three functions:

- ON
- Alarm Silence
- Manual Battery Test

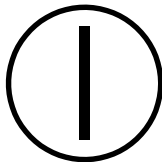

ON - Pressing this button will start up the UPS in order to provide conditioned and protected power.

Alarm Silence - To silence alarms, press this button for at least one Second. After the alarm is silenced, the GXT2-6000RTL630 will reactivate the alarm system to alert of additional problems.



NOTE

The LOW BATTERY and BYPASS reminder alarms CANNOT be silenced.

Manual Battery Test - To initiate a manual battery test, press the ON button for at least one second while operating from utility power with no alarm conditions present.

- If only three of the five Battery LEDs illuminate, allow the UPS to recharge the batteries for 24 hours.
- After 24 hours, retest the batteries.
- After the batteries have been retested, if only three of the five Battery LEDs illuminate, contact your local dealer, Liebert representative or Liebert Worldwide Support Group.

8.2 Standby/Manual Bypass Button

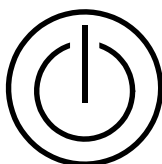

This button controls output power to connected load(s) and has dual functions: Standby and Manual Bypass.



CAUTION

Pressing the Standby/Manual Bypass button once will transfer the load to bypass power. Pressing the Standby/Manual Bypass button a second time within 4 seconds will cut off power to the output receptacles and connected loads. Perform all necessary shutdown procedures on connected loads before pressing this button twice.

8.3 Load Level Indicators (4 Green, 1 Amber)

The load level indicators display the approximate electrical load placed upon the UPS at all times.

8.4 Battery Level Indicators (5 Green)

The battery level indicators display approximate battery capacity at all times.

The GXT2-6000RTL630 is equipped with automatic and remote battery test features. The automatic test occurs every 14 days (this option is user configurable) if utility power has not been interrupted. Should the battery fail this test, the red Fault indicator LED along with the A and C diagnostic LEDs will illuminate and an alarm will sound (refer to **12.0 - Troubleshooting**). The remote test feature functions with MultiLink 3.x software and can remotely initiate the battery test.

8.5 Fault Indicator LED (Red)

The Fault indicator LED is illuminated if the UPS has detected a problem. Also, one or more of the battery level indicators may be illuminated (refer to **12.0 - Troubleshooting**).

8.6 Bypass Indicator LED (Amber)

The Bypass indicator LED is illuminated when the UPS is operating from bypass power. An alarm will sound indicating the UPS detected a problem, or the manual bypass function has been activated.

8.7 UPS ON Indicator LED (Green)

The UPS ON indicator LED is illuminated when the UPS inverter is operating and supplying power to the connected loads.

8.8 Battery Indicator LED (Amber)

The Battery indicator LED is illuminated when the UPS is operating on battery.

8.9 AC Input Indicator LED (Green)

The AC Input indicator LED is illuminated when utility power is available and within the input specifications.

9.0 OPERATING INSTRUCTIONS

9.1 Normal Mode Operation

During normal operation, utility power provides energy to the UPS. The filters, power factor correction circuit and the inverter process this power to provide computer grade power to connected loads. The UPS maintains the batteries in a fully charged state. The four green load level LEDs indicate an approximate level of load in 25% increments. If the UPS becomes loaded beyond full rating, the fifth (amber) LED indicator will illuminate and the UPS will sound an audible alarm. The display template indicates the percentage of load (10% of load shown in example) on the UPS output.

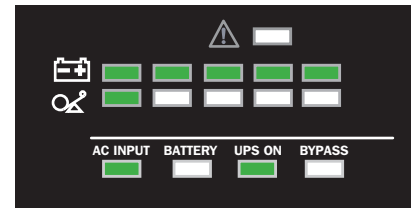

Normal Mode Operation
Batteries at 100% Charge
Load at 10%

9.2 Battery Mode Operation

Battery mode occurs in event of an extreme input voltage condition or complete utility failure. The battery system supplies power through the DC to DC converter to the inverter to generate power for the connected load. During battery mode an alarm sounds every 10 seconds. This will change to two beeps every 5 seconds when the battery runs low (approximately 2 minutes remaining, but this is user configurable). The AC Input LED will extinguish, and the Battery LED will illuminate to warn that a utility problem has occurred. Each battery level indicator represents a 20% capacity level. As capacity decreases, fewer indicators remain illuminated. Refer to **12.0 - Troubleshooting**. For approximate battery run times, refer to **Table 5**. These times are approximate, based on resistive load and an ambient temperature of 77°F (25°C). To increase this time, turn off non-essential pieces of equipment (such as idle computers and monitors) or add the optional external battery cabinet.

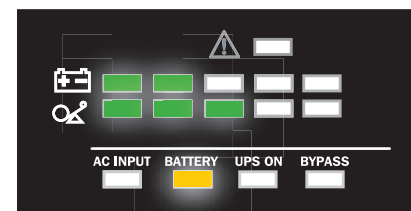

Battery Mode Operation
Batteries at 30% Charge
Load at 50%



CAUTION

Turning OFF the UPS while in it is battery mode will cut off output power.

9.3 Bypass Mode Operation

Bypass mode occurs when the OFF button is pressed once while the UPS is in Normal Mode. During bypass operation, utility power provides energy to the UPS. The utility power bypasses the inverter and provides power for the connected load.

The four green load level LEDs indicate an approximate level of load in 25% increments. If the UPS becomes loaded beyond full rating, the fifth (amber) LED indicator will illuminate and the UPS will sound an audible alarm. The display template indicates the percentage of load (26-50% of load shown in the example above) on the UPS output.

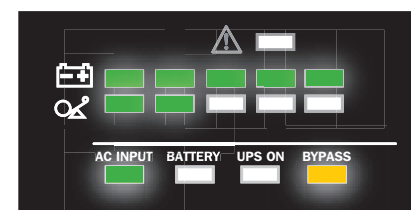

9.4 Battery Recharge Mode

Once utility power is restored, the UPS resumes normal operation. At this time, the Battery Charger begins recharging.

10.0 COMMUNICATIONS

10.1 Communications Interface Port

The GXT2-6000RTL630 has a standard DB-9 serial port female connector located on the rear of the UPS unit. Several signals are provided on this port and are assigned as follows:

Table 1 DB-9 pin assignment

DB-9 Pin	Assignment Description
1	Low Battery (open collector)
2	UPS TxD (typically RS-232 levels)
3	UPS RxD (typically RS-232 levels)
4	Remote Shutdown (5-12VDC, 10-24mA max; battery operation)
5	Common
6	Remote Shutdown (short to pin 5); all modes of operation
7	Low Battery (open emitter)
8	Utility Power Failure (open emitter)
9	Utility Power Failure (open collector)

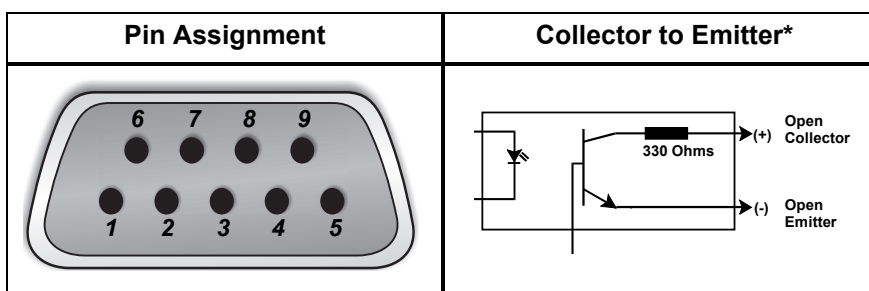

* Maximum voltage and current on pins 1, 7, 8 and 9 are 60VDC and 10.0 mA

10.2 Pin 4 - Remote Shutdown on Battery

1. This pin is functional only when the UPS is in battery mode. If the UPS is being powered by utility power, Pin 4 will ignore any signal on this pin.
2. Pin 4 requires a 5-12 VDC signal to shutdown. This normally comes from the serial port using Liebert's contact closure cable. It cannot be used with just a contact closure unless the relay is used to switch a voltage source. A 5-12 VDC signal for 1.5 seconds or greater is required to signal a shutdown. Signals for less than 1.5 seconds will be ignored. After Pin 4 receives a shutdown signal for 1.5 seconds, the command cannot be canceled.
3. A battery shutdown signal on Pin 4 will NOT cause an immediate Shutdown. A shutdown signal will start a 2-minute shutdown timer. The timer cannot be stopped. After 2 minutes, the UPS will shut down.
4. If utility power returns during the 2-minute timer countdown, the shutdown timer will continue until the end of 2 minutes and the UPS will turn OFF. The UPS must remain OFF for at least 10 seconds even if AC input power Returns before the UPS turns OFF. This serves to reset and restart the server.

Whether the UPS turns back ON when power is restored depends on the auto-restart setting: enabled or disabled.

If the auto-restart is disabled, the UPS will not restart after performing the 2-minute shutdown delay.

10.3 UPS Intelligent Communications

The GXT2-6000RTL630 is equipped with two Intellislot® ports to provide advanced communication and monitoring options.

The Intellislot port closer to the corner of the UPS chassis is the serial card slot. This Intellislot port is used for the OCWEBCARD and the USBCARD. The other Intellislot port is used for RELAYCARD-INT or the MULTIPORT Card.

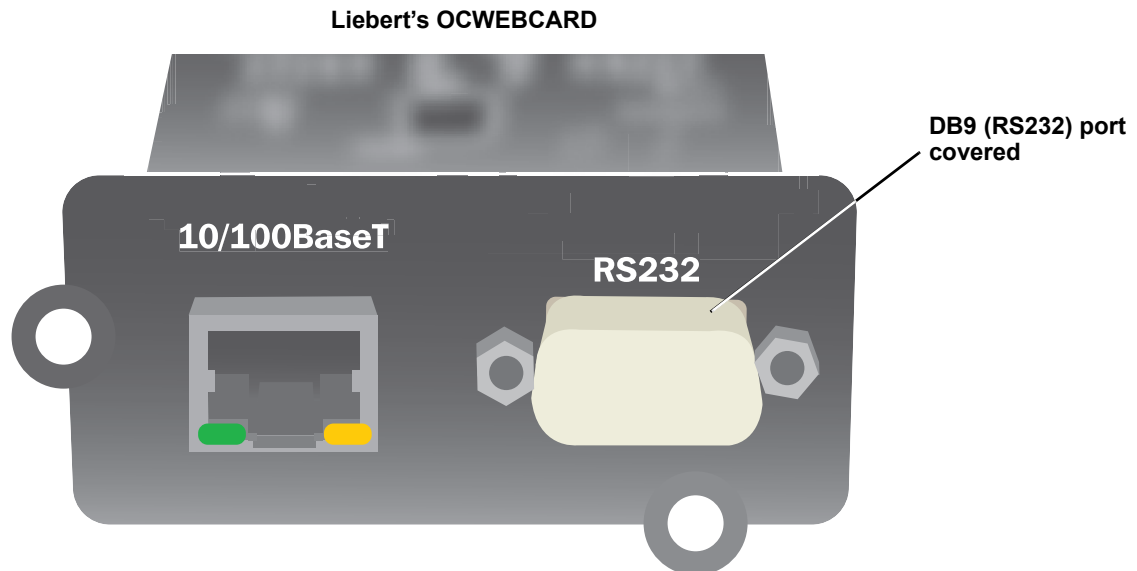

NOTE

The OCWEBCARD DB9 serial port cable should be used only for the initial card setup. Remove the cable after setup is complete.

When the DB9 OCWEBCARD serial port cable is removed, the OCWEBCARD DB9 connector needs to be covered. The DB9 cover is included with the UPS.

Liebert's MultiLink software continually monitors the UPS and can shut down your computer or server in the event of an extended power failure.

MultiLink can also be configured for use without the serial cable when the Intellislot SNMP/Web card is installed in the UPS. Additionally, MultiLink can be configured to coordinate shutdown across the network with other computers running MultiLink when you purchase a MultiLink License Kit. For more information about the Intellislot SNMP/Web Card and MultiLink license Kits, visit our Web site (www.liebert.com) or contact your local dealer or Liebert representative.

Several option cards are available for use in the Intellislot port of the GXT2-6000RTL630. The Intellislot SNMP/Web Card provides SNMP and Web-based monitoring and control of the UPS across the network.

The Intellislot MultiPort 4 Card allows you to install MultiLink software on four computers and coordinate shutdown in the event of a power failure.

The Intellislot Relay Card provides dry contact relay outputs for custom wired applications and delivers support for built-in shutdown for AS/400 systems.



CAUTION

To maintain safety (SELV) barriers and for electromagnetic compatibility, signal cables should be segregated and run separate from all other power cables, where applicable.

10.4 Remote Emergency Power Off

The UPS is equipped with a Remote Emergency Power Off (REPO) connector.

The user must supply a means of interfacing with the REPO circuit to allow disconnecting the UPS input feeder breaker to remove all sources of power to the UPS and connected equipment to comply with national and local wiring codes and regulations.

REPO switch connection diagram

UPS ships with REPO jumper installed allowing the UPS to operate

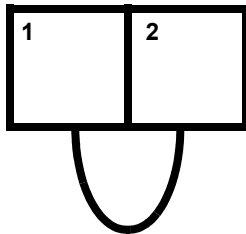

Normally closed switch system
(fail-safe)

Opening the REPO connection will disable the UPS. Manual restart using the front panel is required after the REPO connection is closed again.

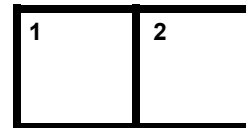

CAUTION

To maintain safety (SELV) barriers and electromagnetic compatibility, signal cables should be segregated and run separately from power cables.

11.0 MAINTENANCE

11.1 Internal Battery

The GXT2-6000RTL630 requires very little maintenance. The batteries are valve-regulated, non-spillable, flame retardant, lead acid, and should be kept charged to obtain their designed life. The UPS continuously charges the batteries when connected to the utility supply.

When storing the UPS for any length of time, it is essential to plug the UPS in for at least 24 hours every four to six months to ensure full recharge of the batteries. Failure to recharge the batteries periodically will result in permanent degradation of battery capacity.

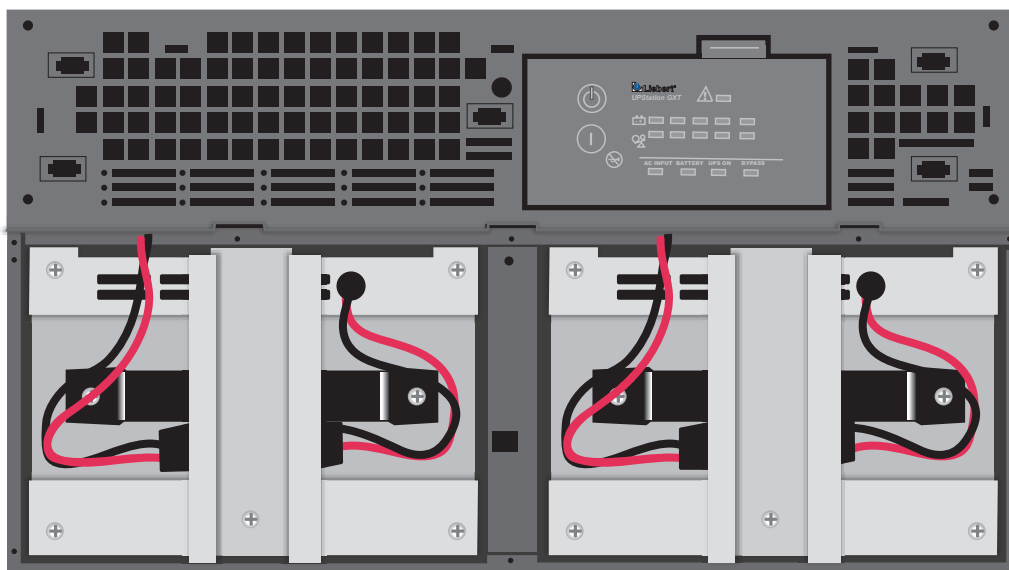

The GXT2-6000RTL630 is designed to allow the user to safely replace the internal batteries. Read the safety cautions before proceeding. Contact your local dealer or Liebert representative to obtain the appropriate replacement battery kit part number and pricing.

11.1.1 Internal Battery Replacement



CAUTION

A battery can present a risk of electrical shock and high short circuit current. Observe the following precautions before replacing the batteries:

- Remove rings, watches and other metal objects.
- Use a Phillips (cross-head) screwdriver with insulated grips.
- Do not lay tools or other metal objects on top of the batteries.
- If the battery replacement kit is damaged in any way or shows signs of leakage, contact your local dealer or Liebert representative immediately.
- Do not dispose of batteries in a fire. The batteries may explode.
- Do not open or mutilate batteries. Released electrolyte is harmful to the skin and eyes. It is toxic.

1. Remove the 3U battery access panel on the front of the UPS by loosening the two captive screws located between the bezels (see illustration at right).
2. Once the captive screws are loosened, tip the panel forward and lift to remove it from the main cabinet.
3. Use a Phillips (cross-head) screwdriver to remove the screw in the battery retaining bracket on each battery pack (see illustration at right). Remove the retaining brackets.
4. Disconnect the battery connectors in the front of each battery pack.
5. Lift the internal connector out of the way and slide the battery out of the UPS. Support the weight of the battery to prevent it from falling.
6. Unpack the new battery assembly, taking care not to destroy the packing. Compare new and old battery assemblies to make sure they are the same. If so, proceed with **Step 7**; otherwise STOP and contact your local dealer, Liebert representative or the Liebert Worldwide Support Group.
7. Line up and slide in the new replacement battery pack while holding the internal connector out of the way.
8. Reconnect the electrical connections for each battery pack.
9. Install the battery retaining brackets using the Phillips removed earlier.
10. Install the battery access panel and tighten the captive screws.



NOTE

These are hot-swappable replacement batteries. However, caution should be exercised because during this procedure the load is unprotected from disturbances and power outages.

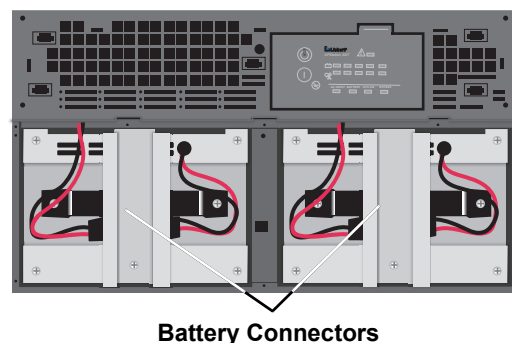
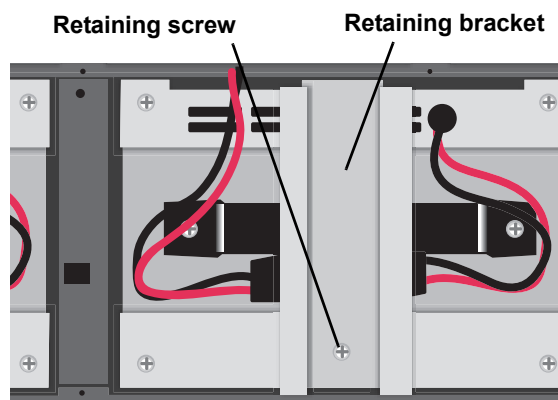
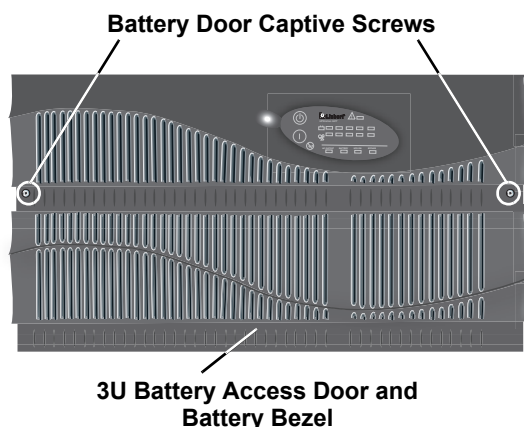

11.2 AC Power Connections

Power connections may be disconnected from the UPS cabinet via a removable distribution box. This may be a convenient feature if the UPS must be moved a short distance or replaced. This box allows power connections to be conveniently disconnected from the main UPS cabinet. A label is attached to the UPS to describe these procedures.

11.2.1 Disconnect

1. DO NOT turn off the branch circuit breaker feeding power the box unless you intend to disconnect all power to the load.
2. Ensure that the Maintenance Bypass Lamp is ON.
3. Switch to the maintenance bypass position.
The load is now unprotected from line disturbances or interruptions.
4. Turn off the UPS using the front panel controls.
 - a. If needed, push the OFF button for one second once to transfer the load to bypass.
 - b. Press the OFF button twice within four seconds to turn the UPS off.
5. Turn off the UPS input circuit breaker on the box at the rear of the UPS.
This input circuit breaker cuts off power only from the connector between the box and UPS. The input circuit breaker does not cut off power from the manual bypass switch.
6. Turn off the output circuit breaker on the rear of the UPS.
7. Remove the distribution box from the UPS
 - a. Loosen all three captive screws until the box releases.
 - b. Pull box away from the UPS and set the box aside on a padded surface.
8. Loosen the cover over the electrical connections by backing out the three screws one turn each.
9. Slide the cover over the electrical connections.
10. Gently retighten the three screws loosened in **Step 8**.
Whenever the power distribution box is not attached to the UPS, the cover must be slid over the electrical connections to prevent damage or injury.



CAUTION

Power is still passing through the power distribution box from the utility supply to the load.

Figure 8 Power distribution box, PD-L630

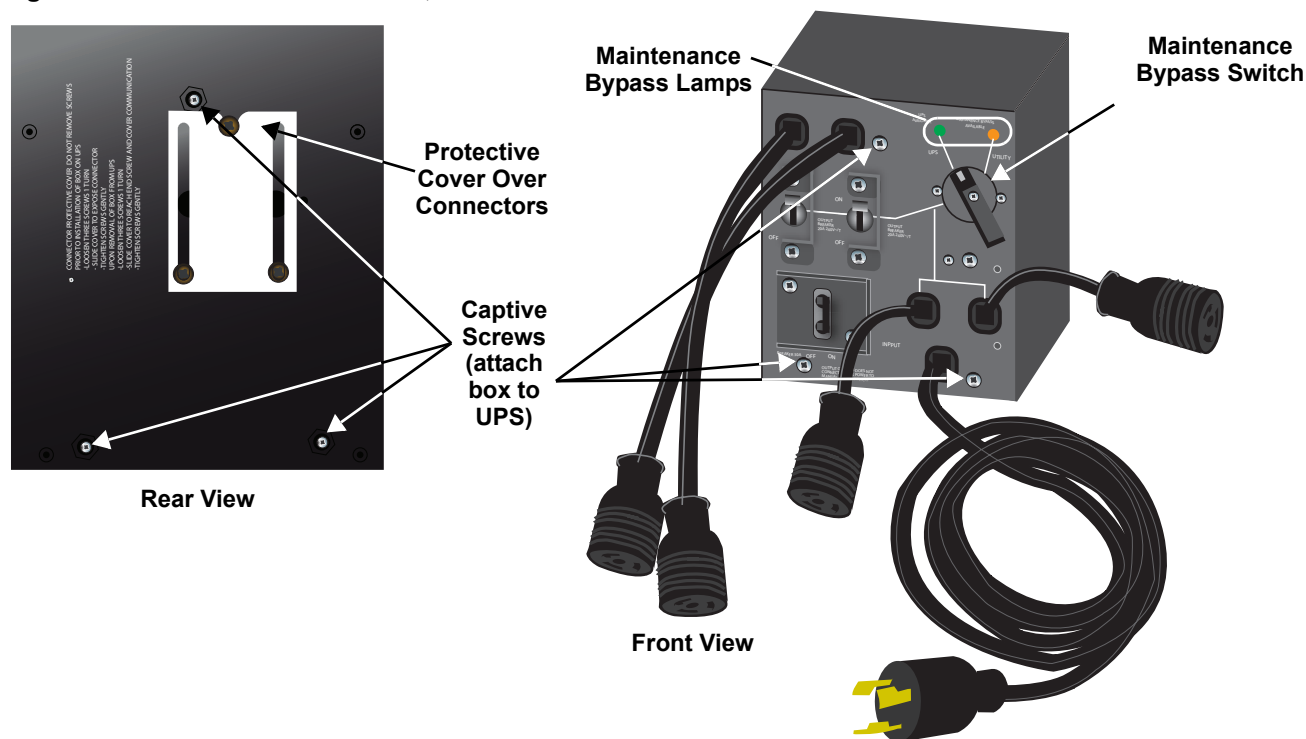

11.2.2 Reconnect

1. Loosen the cover over the electrical connections by backing out the three screws one turn each.
2. Slide the cover open to expose the electrical connectors.
3. Gently retighten the three screws loosened in **Step 1**.
4. Align connectors and press the box onto the rear of the UPS.
5. Hold the box firmly against the UPS and tighten the captive screws. Do not overtighten.
6. If the utility branch circuit breaker and load is off, turn the branch breaker on now.
7. Turn on the output circuit breaker on the rear of the UPS.
8. Turn on the input circuit breaker on the power distribution box.
9. Start the UPS according to the startup instructions.
Press the ON button for one second.
10. Confirm that the UPS AVAILABLE lamp is lit beside the manual bypass switch.
11. Turn the manual bypass switch to the UPS position.
12. The UPS now protects the load.

12.0 TROUBLESHOOTING

The information below indicates various symptoms a user may encounter in the event the GXT2-6000RTL630 develops a problem. Use this information to determine whether external factors caused the problem and how to remedy the situation.

1. The Fault indicator will illuminate, indicating the UPS detected a problem.
2. An alarm will sound, alerting that the UPS requires attention.

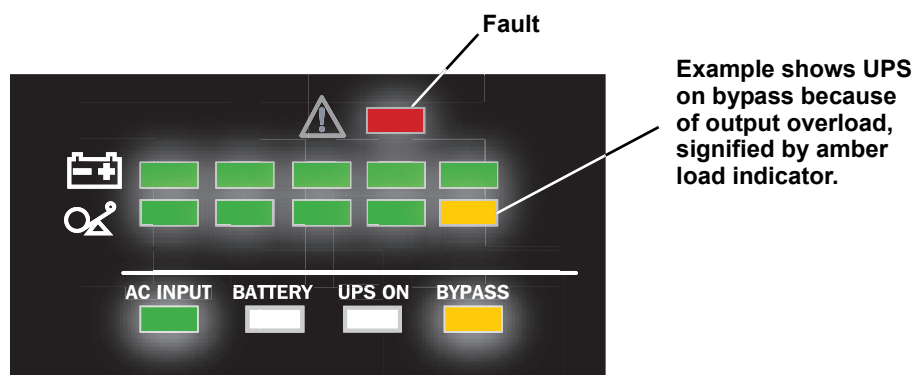

3. One or more additional battery level LED indicators will be illuminated to provide a diagnostic aid to the operator, as described below:

Table 2 Indicator meanings

LED status	Diagnosis/Audible alarm
All LEDs	On bypass due to output overload; beep every half-second
A LED	On bypass due to overtemperature condition; beep every 4 sec.
B LED	On bypass due to DC bus overvoltage; beep every 4 sec.
C LED	DC-DC failure during battery mode; beep every 4 sec.
D LED	On bypass due to PFC failure; beep every 4 sec.
E LED	On bypass due to inverter failure; beep every 4 sec.
A&C LEDs	UPS failed battery test; long beep every minute
C&E LEDs	UPS shutdown due to command from communication port (SNMP); no beep
Battery LED Flashing	Internal Battery source not available (continuous horn). Check Battery connection, completely power down and reboot UPS.
A&E LEDs	Fan locked
B&C	REPO active. UPS cannot run with REPO loop open.
B&D	UPS is OFF due to previous REPO shutdown. Autorestart disabled.
D&E	Charger Malfunction

Under fault conditions, the Fault indicators will be illuminated indefinitely while battery charger is operational, or for a maximum of 5 minutes while the battery charger is not operational.

If a problem persists, consult your local dealer, Liebert representative or contact the Liebert World-wide Support Group. Please have the UPS model number and serial number available at the time of your inquiry.

Table 3 Troubleshooting guide

Problem	Cause	Solution
UPS fails to start when the ON button is pressed.	UPS is short-circuited or overloaded.	Ensure UPS is OFF. Disconnect all loads and ensure nothing is lodged in output receptacles. Ensure loads are not defective or shorted internally.
Battery indicator LED is illuminated.	UPS not plugged in.	UPS is operating from battery mode, make certain UPS is securely plugged into the wall receptacle.
	UPS input protection has opened.	UPS is operating from battery mode. Save data and close applications. Check UPS input circuit breaker, then restart UPS.
	Utility voltage out of UPS input range.	UPS is operating from battery mode. Save data and close applications. Ensure utility supply voltage is within acceptable limits for UPS.
UPS has reduced battery time.	Batteries are not fully charged.	Keep UPS plugged in continuously at least 24 hours to recharge batteries.
	UPS is overloaded.	Check load level display and reduce the load on the UPS.
	Batteries may not be able to hold a full charge due to age.	Replace batteries. Contact your local dealer, Liebert representative or the Liebert Worldwide Support Group for replacement battery kit.
Fault and Bypass indicator LEDs and all load level LEDs are illuminated.	UPS overloaded or load equipment is faulty.	Check load level display and remove non-essential loads. Recalculate the load and reduce number of loads connected to UPS. Check load equipment for faults.
Fault and Bypass indicator LEDs and diagnostic LED A are illuminated.	UPS internal fan has a problem or UPS shutdown due to temperature condition. Load is on bypass power.	Ensure UPS is not overloaded, ventilation openings not blocked, or room ambient temperature is not excessive. Wait 30 minutes to allow UPS to cool, then restart UPS. If UPS does not restart, contact your local dealer, Liebert representative or the Liebert Worldwide Support Group.
Fault and Bypass indicator LEDs and diagnostic LED B are illuminated.	UPS internal DC bus overvoltage.	UPS requires service. Contact your local dealer, Liebert representative or the Liebert Worldwide Support Group.
Fault indicator LED and diagnostic LED C are illuminated.	DC-DC failure during battery mode.	Bus voltage under 315VDC (O/P 220VAC) / 330VDC (O/P 230VAC) / 345VDC (O/P 240VAC). UPS requires service. Contact your local dealer, Liebert representative or the Liebert Worldwide Support Group.
Fault and Bypass indicator LEDs and diagnostic LED D are illuminated.	UPS PFC (Power Factor Correction Circuit) fault.	UPS requires service. Contact your local dealer, Liebert representative or the Liebert Worldwide Support Group.
Fault and Bypass indicator LEDs and diagnostic LED E are illuminated.	UPS inverter fault.	UPS requires service. Contact your local dealer, Liebert Representative or the Liebert Worldwide Support Group.
Fault indicator LED and diagnostic LEDs A and C are illuminated.	UPS failed the battery test.	Replace batteries. Contact your local dealer, Liebert representative or the Liebert Worldwide Support Group.
Fault and Bypass indicator LEDs and diagnostic LED C and E are illuminated.	UPS shutdown due to a command from the communications port(s).	Your UPS has received a signal or command from the attached computer. If this was inadvertent, ensure the communication cable used is correct for your system. For assistance, contact your local dealer, Liebert representative or the Liebert Worldwide Support Group.
Fault and LEDs A&E are illuminated	Fan locked	Check for external obstruction entering fan guard. UPS requires service. Contact your local dealer, Liebert representative or Liebert Worldwide Support Group.
Fault and LEDs B&C are illuminated	REPO active	REPO circuit loop is open. If not used, a wire jumper must connect the REPO terminals.
Fault and LEDs B&D are illuminated	UPS is OFF due to previous REPO shutdown, but the REPO has been connected or reset. Autorestart disabled.	Start the UPS using the front panel.

Table 3 Troubleshooting guide (cont'd)

Problem	Cause	Solution
Fault and LEDs D&E are illuminated	Charger malfunction	If the charger is overvoltage, the UPS will shutdown. If the charger is undervoltage and the batteries are nearly depleted, this alarm will give a temporary warning before the UPS shuts down. UPS requires service. Contact your local dealer, Liebert representative or Liebert Worldwide Support Group.
Battery LED is flashing.	Battery source is not available; continuous horn.	Check battery connections, completely power down and restart UPS. NOTE: If the battery circuit opens while the UPS is running, it will be detected when the next battery test is performed.

Table 4 Alarm conditions

Condition	Alarm
Battery Mode (utility failure)	One short beep every 10 seconds: more than 2 minutes of run time remaining
Low Battery	Two short beeps every 5 seconds: less than 2 minutes of run time remaining
Output Overload (Bypass)	One short beep every half second
Overtemperature (Bypass)	A one-second beep every 4 seconds
DC Bus Overvoltage (Bypass)	A one-second beep every 4 seconds
DC-DC failure during battery mode	A one-second beep every 4 seconds
PFC Failure (Bypass)	A one-second beep every 4 seconds
Inverter Failure	A one-second beep every 4 seconds
Battery Test Failure	A two-second beep every 1 minute
Fan Locked	A one-second beep every 4 seconds
REPO Active	A 0.25-second beep every 0.25 seconds
UPS OFF; Autorestart disabled from previous REPO shutdown	A one-second beep every 4 seconds
Charger Malfunction	A one-second beep every 4 seconds

Table 5 Battery run times

	Load%	6000VA
Internal Battery (minutes)	10%	94
	20%	46
	30%	29
	40%	21
	50%	17
	60%	13
	70%	11
	80%	9
	90%	8
	100%	7
Internal Battery + 1 External Battery Cabinet (minutes)	10%	222
	20%	124
	30%	81
	40%	60
	50%	49
	60%	39
	70%	33
	80%	28
	90%	24
	100%	21
Internal Battery + 2 External Battery Cabinets (minutes)	10%	350
	20%	197
	30%	135
	40%	105
	50%	85
	60%	70
	70%	58
	80%	50
	90%	43
	100%	38
Internal Battery + 3 External Battery Cabinets (minutes)	10%	478
	20%	269
	30%	185
	40%	145
	50%	123
	60%	101
	70%	85
	80%	73
	90%	63
	100%	55
Internal Battery + 4 External Battery Cabinets (minutes)	10%	606
	20%	341
	30%	235
	40%	184
	50%	156
	60%	131
	70%	113
	80%	97
	90%	85
	100%	75

Using the configuration program, the user may specify the number of GXT2-240VBATTUL external battery cabinets attached to the UPS. The factory default is programmed for internal batteries only.

Table 5 above shows the estimated run times at different loads.

12.0.1 Auto-Learning Battery Run Times

As batteries age, the estimated runtimes may become less accurate. The GXT2-6000RTL630 is programmed to “learn” from a full battery discharge and modify the estimated runtime for the measured battery capacity. This can improve accuracy and compensate for aging batteries or batteries that operate at different ambient temperatures.

The UPS will update the anticipated run time calculation only under certain conditions.

- The UPS must have a steady load that is greater than 20%.
- The UPS must be at 100% charge at the start of a battery discharge.
- The battery discharge must continue uninterrupted until the batteries reach their end-of-discharge voltage.

If all conditions are not met, the run time calculation will not be modified.

If the configuration program is used to change the number of battery cabinets, then the values in the battery above table will be restored. This will override any value that is Auto-Learned.

13.0 SPECIFICATIONS

Table 6 UPS specifications

Model Number	GXT2-6000RTL630
Model Rating	6000VA/4200W
Dimensions, in. (mm)	
Unit, W x D x H	8.7 x 21.5 x 16.9 (221 x 547 x 430)
Shipping, W x D x H	22.0 x 27.2 x 19.7 (560 x 690 x 500)
Weight, lb (kg)	
Unit	57.2 (26)
Shipping	81.5 (37)
Input AC Parameters	
Nominal Operating Frequency	50 or 60Hz (Factory Default = 60)
Factory Default VAC	208VAC
User Configurable VAC	208/220/230/240VAC (May be modified using configuration program)
Operating Voltage Range Without Battery Operation	176 – 276VAC
Maximum Allowable VAC	276VAC
Input Frequency Without Battery Operation	40 - 70Hz
Input Power Connection	L6-30P Plug (on PD-L630 power distribution box)
Output AC Parameters	
Factory Default VAC	208VAC
Output Connections	(2) L6-20R and (2) L6-30R on 12" (300mm) cords (on PD-L630 power distribution box)
Frequency	50Hz or 60Hz, Nominal
Waveform	Sinewave
Main Mode Overload	>200% for 96 milliseconds; 131 - 199% for 2 seconds; 112- 129% for 10 seconds with transfer to bypass
Bypass Protection Limits	
Disable Bypass operation	If input voltage exceeds $\pm 15\%$ of the nominal voltage
Re-enable Bypass operation	If input voltage returns to within $\pm 10\%$ of nominal output voltage
Disable Bypass operation	When the input frequency prevents synchronous operation
Environmental	
Operating Temperature	32°F to 104° F (0°C to 40°C)
Storage Temperature	5°F to 122° F (-15°C to 50°C)
Relative Humidity	0-95% non-condensing
Operating Elevation	Up to 6600 ft (2000m) at 104°F (40°C) without derating 50,000 ft. (15,000m) maximum
Storage Elevation	
Audible Noise	<55 dBA, at 3 ft. (1m) from the rear <50 dBA, at 3 ft. (1m) from the front or sides
Agency	
Safety	UL, C-UL Listed to UL1778
EMI/EMC	FCC Class B
ESD	EN61000-4-2, Level 4, Criteria A
Radiated Susceptibility	EN61000-4-3, Level 3, Criteria A
Electrical Fast Transient	EN61000-4-4, Level 4, Criteria A
Surge Immunity	EN61000-4-5, Level 3, Criteria A
Transportation	ISTA Procedure 1B

Table 7 Internal battery specifications

Model Number	GXT2-240BATKIT
Dimensions, W x D x H, in. (mm)	
Shipping	21.2 x 12.2 x 16.2 (539 x 311 x 412)
Weight, lb (kg)	
Unit	44.5 (20.2) each, (2 required)
Shipping	93.9 (42.6), (2 batteries in a single carton)
Type	Valve-regulated, non-spillable, lead acid
Quantity x V	20 x 12V
Battery Mfr. / Part #	Yuasa / REW 28-12FT
Electrical Characteristics	
Back-up Time	See Table 5 - Battery run times
Recharge Time	3 hrs. to 90% capacity after full discharge into 100% load

Table 8 Output distribution specifications

Model Number	PD-L630
Dimensions, W x D x H, in. (mm)	
Unit	5.3 x 6.9 x 3.5 (134 x 175 x 88)
Shipping	8.9 x 10.4 x 12.4 (225 x 265 x 315)
Weight, lb (kg)	
Unit	30 (13.5)
Shipping	33 (15)
Electrical Specifications	
Amp Rating	24 Amps
Input Power Connections	L6-30P on 10-foot (3m) cord
Output Power Connection: L1-L2-G	(2) L6-30R on a 12" (300mm) cord (2) L6-20R on a 12" (300mm) cord

Table 9 External battery cabinet specifications

Model Number	GXT2-240VBATTUL
Used w/ UPS model	GXT2-6000RTL630
Dimensions, W x D x H, in. (mm)	
Unit (with bezel)	6.9 x 20.6 x 16.9 (176 x 522 x 430)
Shipping	22.0 x 27.2 x 17.9 (560 x 690 x 455)
Weight, lb (kg)	
Unit	145 (65)
Shipping	173.1 (78.5)
Battery Parameters	
Type	Valve-regulated, non-spillable, flame retardant, lead acid
Qty x V	20 x 12V
Battery Manufacturer, Part #	Yuasa / REW 45-12
Backup Time	See Table 5 - Battery run times
Environmental	
Operating Temp	32°F to 104°F (0°C to 40°C)
Storage Temp	5°F to 122° F (-15°C to 50°C)
Relative Humidity	0-95% non-condensing
Operating Elevation	Up to 6600 ft. (2000m) at 104°F (40°C) without derating
Storage Elevation	50,000 ft. (15,000m) maximum
Agency	
Safety	UL, C-UL Listed to UL1778
Transportation	ISTA Procedure 1B

Ensuring The High Availability Of Mission-Critical Data And Applications.

Emerson Network Power, the global leader in enabling business-critical continuity, ensures network resiliency and adaptability through a family of technologies—including Liebert power and cooling technologies—that protect and support business-critical systems. Liebert solutions employ an adaptive architecture that responds to changes in criticality, density and capacity. Enterprises benefit from greater IT system availability, operational flexibility and reduced capital equipment and operating costs.

Technical Support / Service Web Site

www.liebert.com

Monitoring

800-222-5877

monitoring@emersonnetworkpower.com

Outside the US: 614-841-6755

Single-Phase UPS

800-222-5877

upstech@emersonnetworkpower.com

Outside the US: 614-841-6755

Three-Phase UPS

800-543-2378

powertech@emersonnetworkpower.com

Environmental Systems

800-543-2778

Outside the United States

614-888-0246

Locations

United States

1050 Dearborn Drive

P.O. Box 29186

Columbus, OH 43229

Europe

Via Leonardo Da Vinci 8

Zona Industriale Tognana

35028 Piove Di Sacco (PD) Italy

+39 049 9719 111

Fax: +39 049 5841 257

Asia

7/F, Dah Sing Financial Centre

108 Gloucester Road, Wanchai

Hong Kong

852 2572220

Fax: 852 28029250

While every precaution has been taken to ensure the accuracy and completeness of this literature, Liebert Corporation assumes no responsibility and disclaims all liability for damages resulting from use of this information or for any errors or omissions.

© 2007 Liebert Corporation

All rights reserved throughout the world. Specifications subject to change without notice.

® Liebert and the Liebert logo are registered trademarks of Liebert Corporation. All names referred to are trademarks or registered trademarks of their respective owners.

SL-23452_REV0_04-07

Emerson Network Power.

The global leader in enabling *Business-Critical Continuity*.

- | | | | |
|----------------|----------------------|------------------------------|-------------------------------|
| ■ AC Power | ■ Embedded Computing | ■ Outside Plant | ■ Racks & Integrated Cabinets |
| ■ Connectivity | ■ Embedded Power | ■ Power Switching & Controls | ■ Services |
| ■ DC Power | ■ Monitoring | ■ Precision Cooling | ■ Surge Protection |

Business-Critical Continuity, Emerson Network Power and the Emerson Network Power logo are trademarks and service marks of Emerson Electric Co.

©2007 Emerson Electric Co.